

Reverse Battery Protection

by Marco Pürschel

Automotive Powe

Never stop thinking.



Table of Content

- 1. Abstract 1
- 2. Introduction 1
- 3. Possible Solutions..... 1
- 3.1. Reverse Battery Protection with Diode.. 1
- 3.2. Reverse Battery Protection with n-channel MOSFET 2
- 3.3. Reverse Battery protection with p-channel MOSFET 3
- 4. Conclusion 4

1. Abstract

This Application Note is intended to provide an overview of reverse battery protection in automotive applications. The pros and cons of each solution will be discussed.

2. Introduction

By changing the battery of a car or during maintenance work on the electronic system of a car, the battery has to be reconnected. During this event, it is possible that the polarity of the battery could be applied in reversal direction. Today's battery terminals are marked with colours and the terminal post itself are mechanically different, nevertheless the possibility for reverse battery is still present, at least for short connection duration.

With reverse applied voltage, shorts via diodes or transistors could occur leading to fatal errors of the electronics of the car. This means, that the ECUs (Electronic Control Unit) have to be protected against reversal battery polarity.

3. Possible Solutions

In this chapter three most common reverse battery protection circuits will be discussed. A solution with relay is not taken into account.

3.1. Reverse Battery Protection with Diode

The easiest way for reverse battery protection would be a series diode in the positive supply line of the ECU accordingly the load. By applying the battery in the wrong polarity the pn junction of the diode blocks the battery voltage and the electronic is protected.

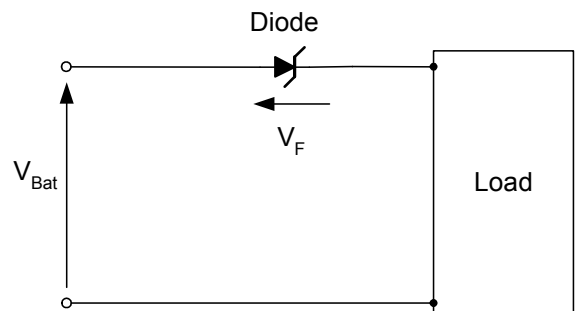

Figure 1: Solution with diode

From a correctly installed battery the supply current is flowing in forward direction through the diode to the load.

Power losses of the diode can be calculated easily with its forward voltage drop characteristic.

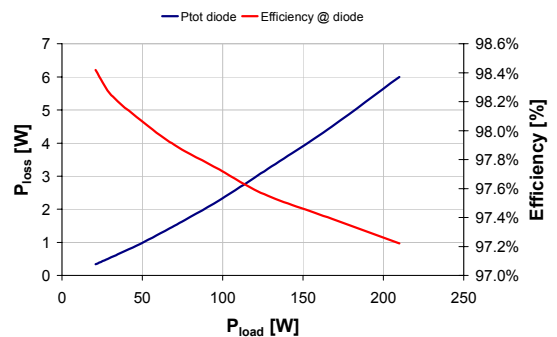

Figure 2: $P_{tot} = f(P_{load})$ for diode solution

Figure 2 shows an example of a solution using 45V rated Schottky diode(s). The total power losses as a function of the power rating of the load with the assumption of a battery voltage of 14V are shown. If the power losses at high output powers can not be handled by one diode, several devices have to be switched in parallel. Due to the diode threshold, which is a constant, switching the devices in parallel the power losses itself will stay more or less at the same level. They will be distributed only accordingly to the amount of used diodes.

3.2. Reverse Battery Protection with n-channel MOSFET

To lower the power losses of the reverse battery protection, a MOSFET can be used. Inserting such a device in the right direction in the positive supply line can protect the load against reversal battery as well. Note that a MOSFET has always an intrinsic anti parallel body diode.

The MOSFET is fully turned on when applying the battery in the right direction. Due to the fact, that the Source is on high potential, the MOSFET is a high side switch not referring to ground. A charge pump circuit (or something equivalent) is needed to boost the Gate-voltage over the Source-voltage to turn the MOSFET on.

During reverse polarity of the battery, the diode in the ground line of the charge pump blocks the voltage. No voltage supplies the Gate and the MOSFET will be switched off. The diode protects as well the charge pump against reversal battery. Otherwise a short via the two transistors would occur.

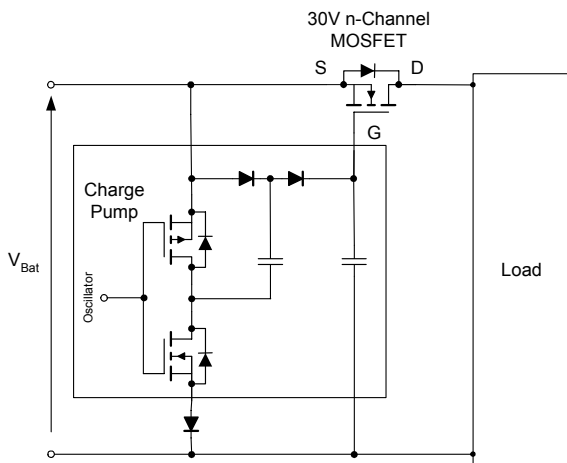

Figure 3: Solution with n-channel MOEFT

Figure 3 shows a typical solution for reverse battery protection with an n-channel MOSFET. The power losses of an n-channel MOSFET for a reverse battery protection are determined by the $R_{DS(on)}$ of the device and the load current. Switching losses can be neglected because the device will be switched on once when the battery is applied and stays in on state during normal operation. The power losses and ratio of power losses versus output power are shown in Figure 4 with an example of a 30V, 3.3mOhm MOSFET (SPP100N03S2-03).

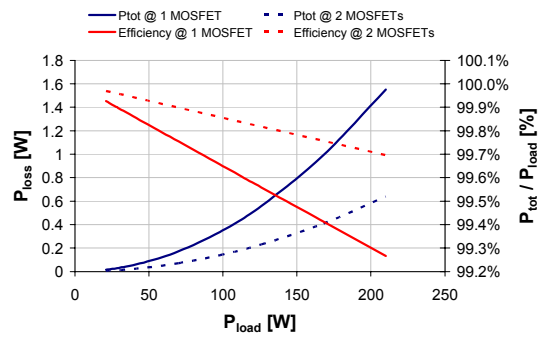

Figure 4: $P_{tot} = f(P_{load})$ for n-channel MOSFET (1 and 2 in parallel) solution

The power losses of the MOSFET are increasing by the power of two over the output power and decreasing linear by the size of the MOSFET. Meaning by switching two MOSFETs in parallel the power losses will be reduced by a factor of two. This means by switching n MOSFETs in parallel, the total power losses will be reduced by a factor of n and the power losses which has to be handled by each MOSFET will be reduced by n^2 .

Such a solution would be feasible for high output power requirements.

The drawback of this solution is the additional circuit effort which has to be spent to drive the n-channel MOSFET during normal operation. A charge pump circuit is needed to create the required offset on the Gate pin over the battery line.

EMI is an issue because the oscillator of the charge pump circuit is switching the two MOSFETs alternating. But the power which will be handled by the charge pump is not a huge one because the power MOSFET is switched on only once. This means that the EMI is not as high as it is normally by dealing with such circuits.

It is not useful in automotive applications to insert the MOSFET in the ground line to get rid of the high side driver. The voltage drop over the MOSFET would result in a shift of the ground level. For sensitive loads this can lead to malfunction.

3.3. Reverse Battery protection with p-channel MOSFET

The third solution to achieve reverse battery protection would be to connect a p-channel MOSFET in the positive supply line of the load. It is again important to insert the transistor in the right direction, because the p-channel MOSFET has as well an intrinsic anti parallel body diode. Note: For a p-channel MOSFET the diode is in forward direction from Drain to Source.

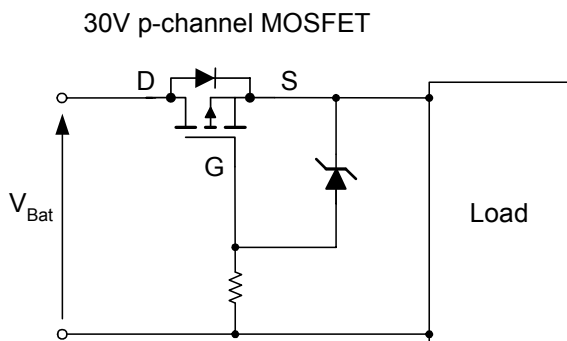

Figure 5: Solution with p-channel MOSFET

The huge benefit by using a p-channel MOSFET belongs to the fact, that no additional high side driver circuit is needed. Compared to an n-channel MOSFET the device will be turned on by applying a negative Gate Source voltage. By referring the Gate signal to the ground line, the device is fully turned on when the battery is applied in the right polarity. For the first start up, the intrinsic body diode of the MOSFET will conduct, till the channel is switched on in parallel. The Zener diode will clamp the Gate of the MOSFET to its Zener voltage and protects it against over voltage.

By reverse polarity, the MOSFET will be switched off, because the Gate Source voltage for this case will be positive (voltage drop over the Zener diode).

The main difference in terms of technology between an n-channel MOSFET and a p-channel MOSFET is the inverse doping profile over the whole device as it can be seen in Figure 6.

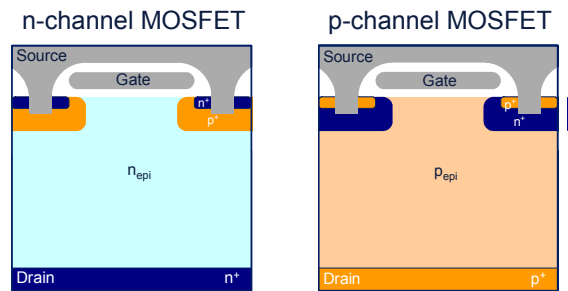

Figure 6: Cross section of a n-channel and p-channel MOSFET

To switch on a p-channel MOSFET a negative Gate Source voltage has to be applied. The electrical field will push the electrons in the channel region back and will attract the holes, the “p-channel” is created and a load current can flow through the device. But this current is a hole current and not an electron current as for an n-channel MOSFET. Holes do not have the same mobility of electrons. It is much harder to push them through the device, resulting in a higher area specific on state resistance. In the past this was a blocking point for the use of a p-channel MOSFET because you have to replace an n-channel MOSFET with a two to three times larger p-channel. With today’s technologies it is possible to shrink the p-FET and the price is going down accordingly.

The power losses of a p-channel MOSFET versus the output power and the efficiency are shown in Figure 7. By switching several MOSFETs in parallel the same effect is valid as for n-channel MOSFETs. The power losses of each device are decreasing with a dependency of n^2 .

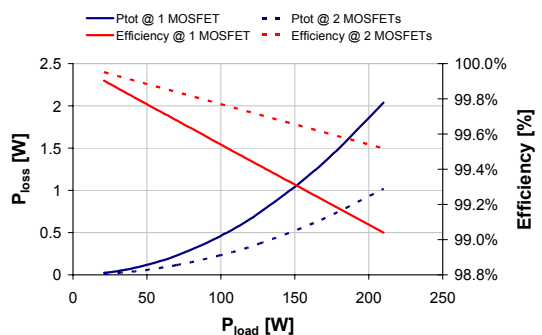

Figure 7: $P_{tot} = f(P_{load})$ for p-channel MOSFET solution

4. Conclusion

This application note points out the three most common ways to achieve reverse battery protection which are:

- solution with a diode
- solution with an n-channel MOSFET
- solution with a p-channel MOSFET

Each solution has its advantages and drawbacks.

	diode	n-channel MOSFET	p-channel MOSFET
Parts	+	-	0
EMI	+	-	+
Power losses	--	++	+
Efficiency	--	++	+
High power	--	++	+

The table is summarizing the pros and cons of the three described solutions. For high power applications the diode is not feasible for reverse battery protection, since power losses are much too high.

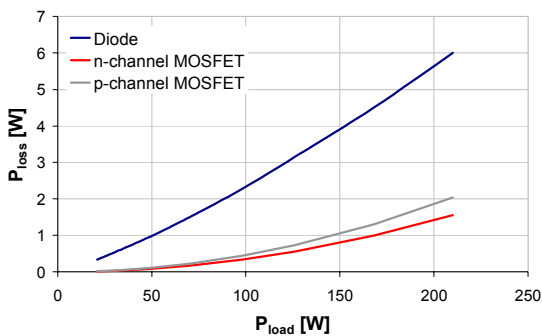

Figure 8: Comparison of power losses for the three solutions

For such applications, the n-channel MOSFET solution offers the highest efficiency with the drawback of additional circuit requirements like a charge pump circuit and EMI filter.

A very simple solution still with an excellent efficiency would be the p-channel approach. Nearly no additional circuit effort compared to the diode and only a slightly worse efficiency in comparison to the n-channel MOSFET makes this solution very attractive.

With the introduction of p-channel MOSFETs in a trench technology the performance of the device increased dramatically and compensates

the disadvantage of the hole mobility significantly.

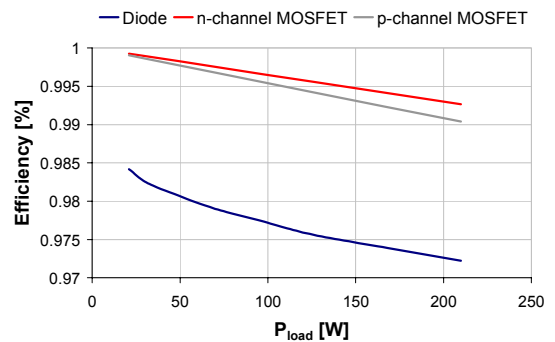

Figure 9: Comparison of efficiency for the three solutions

The best solution for reverse battery will be determined by the requirements of the application. The designer will have to find the trade off between power losses and the effort to spend on the reverse battery protection schematic itself.

**Published by Infineon Technologies AG,
St.-Martin-Strasse 53,
81669 München**

**© Infineon Technologies AG 2004.
All Rights Reserved.**

Attention please!

The information herein is given to describe certain components and shall not be considered as a guarantee of characteristics.

Terms of delivery and rights to technical change reserved.

We hereby disclaim any and all warranties, including but not limited to warranties of non-infringement, regarding circuits, descriptions and charts stated herein.

Information

For further information on technology, delivery terms and conditions and prices please contact your nearest Infineon Technologies Office (www.infineon.com).

Warnings

Due to technical requirements components may contain dangerous substances. For information on the types in question please contact your nearest Infineon Technologies Office.

Infineon Technologies Components may only be used in life-support devices or systems with the express written approval of Infineon Technologies, if a failure of such components can reasonably be expected to cause the failure of that life-support device or system, or to affect the safety or effectiveness of that device or system. Life support devices or systems are intended to be implanted in the human body, or to support and/or maintain and sustain and/or protect human life. If they fail, it is reasonable to assume that the health of the user or other persons may be endangered.

<http://www.infineon.com>

Published by Infineon Technologies AG